

SM

SM

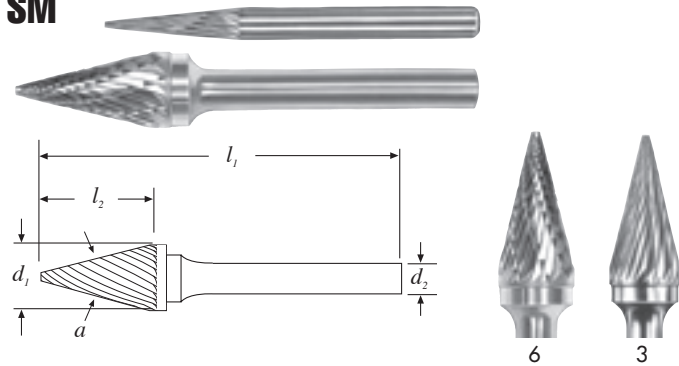

E

Cone (SM) and Inverted Cone (SN) Shape Burs Solid Carbide

* 8mm shanks optional. To Order Optional Cuts 4, 3SP, 2, 5 - Specify Quantity, Tool No. & Optional Cut.

ES

Limas rotativas (SM) cónicas (SN) cónica invertida

Metal duro

* Mango de 8 mm opcional. Para ordenar cortes opcionales 4, 3SP y 2, 5 : Especifique la cantidad, no. de herramienta y tipo de corte opcional.

FR

Fraises-limes (SM) de forme conique et conique inversée (SN)

Carbure monobloc

* Queue de 8 mm en option. Pour commander les coupes en option 4, 3SP, 2, 5 : indiquer la quantité, le N° d'outil et la coupe.

Tool No.	ød ₁ mm	ød ₂ mm	l ₁ mm	l ₂ mm	α	EDP No.	EDP No.
SM-41M	3	3	38	8,9	12°	25678	25675
SM-42M	3	3	38	11	14°	25703	25700
SM-42ML2	3	3	50	11	14°	28053	28050
SM-42ML3	3	3	75	11	14°	28078	28075
SM-43M	3	3	38	16	7°	25728	25725
SM-53M	5	3	38	12,7	16°	25778	25775
SM-1M	6	6	50	12,7	22°	25503	25500
SM-2M	6	6	50	19	14°	25528	25525
SM-3M	6	6	50	25	10°	25553	25550
SM-51M	6,3	3	54	12,7	22°	25753	25750
SM-4M	9,5	6	63	16	28°	25578	25575
SM-5M	12,7	6	69	22	28°	25603	25600
*SM-6M	16	6	73	25	31°	25628	25625

SN

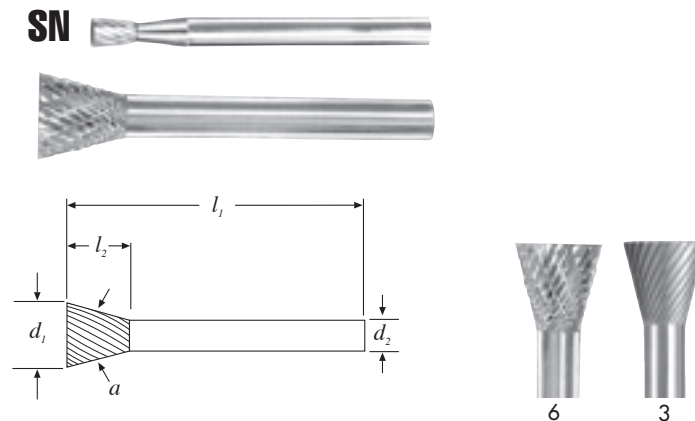

Tool No.	ød ₁ mm	ød ₂ mm	l ₁ mm	l ₂ mm	α	EDP No.	EDP No.
SN-41M	2,5	3	38	3	10°	26028	26025
SN-42M	3	3	38	4	10°	26053	26050
SN-53M	5	3	38	6,3	10°	26103	26100
SN-1M	6	6	50	8	10°	25853	25850
SN-51M	6,3	3	44	6	10°	26078	26075
SN-2M	9,5	6	53	9,5	13°	25878	25875
SN-4M	12,7	6	57	12,7	28°	25903	25900
* SN-6M	16	6	63	19	18°	25928	25925
* SN-7M	19	6	60	16	30°	25978	25975

TECHNICAL

